

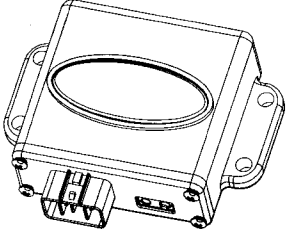
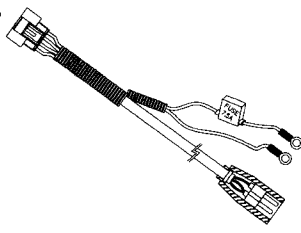

INSTALLATION GUIDE

| | | | |
|--|--|---|---|
| <p>RF-24C Wireless Remote Control For Automotive Winches</p> | <p>1.</p>  | <p>2.</p>  | |
| <p>Wireless Control Kit includes:</p> <ol style="list-style-type: none"> 1. Wireless Receiver.881103 2. Switch Cord W/6P plugs Ø8 X 1500 mm 3. Wireless Transmitter.881102 4. Lithium Battery: 3V CR2032 5. Handsaver Strap | <p>3.</p>  | <p>4.</p>  | <p>5.</p>  |

I.Specifications

1. Transmission range:15 ~ 27 m (50 ~ 90 ft)
2. Receiver operation voltage: 8 ~ 24 V
3. Receiver fuse current rating: 7.5 A
4. Protection: IP-66
5. Operating temperature range: -20°C ~ +70°C

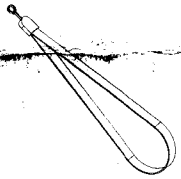
II.Installation Guide

Step 1: Connect the wiring

- a. Connect the Switch cord W/6P plugs to the socket on the control pack.
- b. Slice the Red wire to the receiver fuse then connect to the positive (+) terminal of the battery.
- c. Connect the Black wire to the negative (-) terminal of the battery.

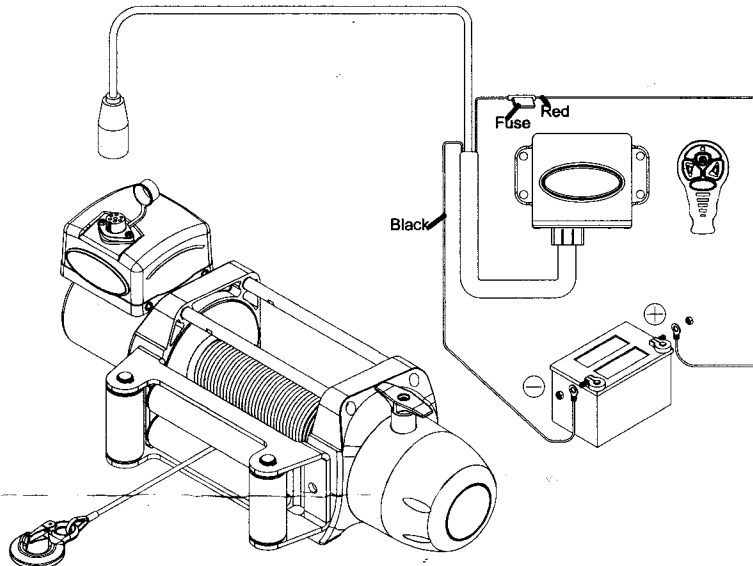

Step 2: Mount the Receiver

- a. The receiver should be mounted in a clear and dry location.
- b. Mount on a flat surface with 2 pieces of Ø7 mm mounting holes on each side of the receiver.

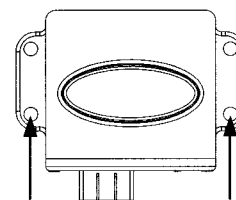

Minimum of one mounting hole each side

III Operation

1. Install and replace battery.
 - a. Remove the three screws from the wireless transmitter.
 - b. Separate the top section and remove the old battery and dispose it.
 - c. Insert new battery and join the top section with the bottom section.
 - d. Make sure to fasten the three screws.

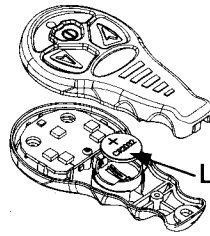
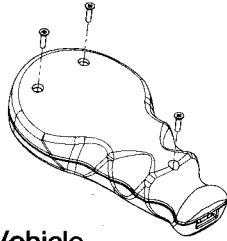

Lithium Battery: CR2032 (3V)

2. Start

- a. Turn on the **Vehicle**.
- b. Press the Power Buttons for 5 seconds until Green light comes on.
- c. Press the Cable In or Cable Out button, then the Red light comes on.

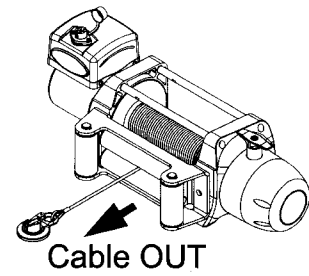
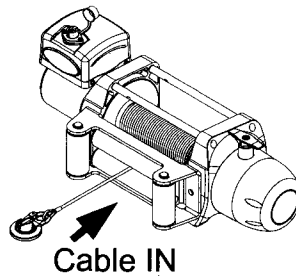
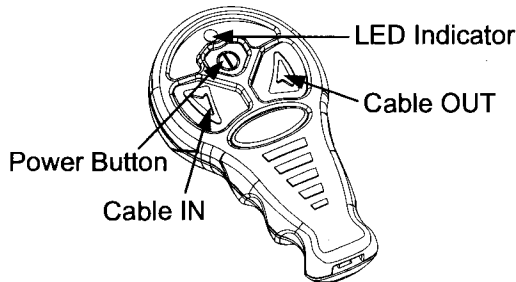

3. Stop

- a. The system will be automatically shutting down the operation after a silence of operation for 5 minutes.
- b. Press and hold the Power Button for 5 seconds for shutting down the operation.

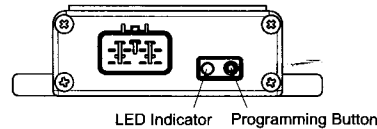

4. Reset

- a. Press and hold the Programming Button for 5 seconds until the Red lights up.
- b. Press the Power Buttons for 5 seconds until the Green lights up.
- c. Press the Cable In or Out button until the Red lights on the receiver turns off.
- d. Reset is now completed. Please note only one remote can be reset for each receiver.

5. Notes

- a. The wireless remote control and handlebar rocker switch can be exchanged for activating the winch, but it takes about 10 seconds for exchanging.
- b. Blinking Green LED light shows batter low, the battery should be replaced immediately.
- c. Please note only one remote can be reset for each receiver.
- d. Blinking Red LED for poor signal.

FCC and Industry Canada (IC) Warning:

• This device complies with Part 15 of the FCC Rules. Operation is subject to the following two conditions: (1) This device may not cause harmful interference, and (2) this device must accept any interference received, including interference that may cause undesired operation.

FEDERAL COMMUNICATIONS COMMISSION INTERFERENCE STATEMENT

This equipment has been tested and found to comply with the limits for a Class B digital device, pursuant to part 15 of the FCC Rules. These limits are designed to provide reasonable protection against harmful interference in a residential installation. This equipment generates, uses and can radiate radio frequency energy and, if not installed and used in accordance with the instructions, may cause harmful interference to radio communications. However, there is no guarantee that interference will not occur in a particular installation. If this equipment does cause harmful interference to radio or television reception, which can be determined by turning the equipment off and on, the user is encouraged to try to correct the interference by one or more of the following measures:

- Reorient or relocate the receiving antenna.
- Increase the separation between the equipment and receiver.
- Connect the equipment into an outlet on a circuit different from that to which the receiver is connected.
- Consult the dealer or an experienced radio/ TV technician for help.

CAUTION:

Any changes or modifications not expressly approved by the grantee of this device could void the user's authority to operate the equipment.